

HP 423B  
HP 8470B

# OPERATING AND SERVICE MANUAL

## 423B 8470B CRYSTAL DETECTOR



Printed: FEBRUARY 1979  
© Hewlett-Packard Co. 1975, 1977

HEWLETT  PACKARD

HP 423B  
HP 8470B

## 1. GENERAL INFORMATION

2. This manual contains operating instructions for the Hewlett-Packard Model 423B and 8470B Crystal Detectors. Included in the manual is the information required to install and test the crystal detectors.

3. On the rear cover of this manual, below the manual part number, is a "Microfiche", part number. This number may be used to order a 4 x 6-inch microfilm transparency of the manual.

## 4. Specifications

5. Instrument specifications are listed in Table 1. These specifications are the performance standards, or limits against which the instrument may be tested.

## 6. Description

7. The Hewlett-Packard Model 423B and 8470B Crystal Detectors are  $50\Omega$  (nominal) devices designed for measurement use in coaxial systems. The instruments convert RF power levels applied to the  $50\Omega$  input connector into proportional values of dc voltage. The instruments measure relative power up to 200 mW and have a BNC female connector for the output jack which allows the detected output to be connected to a SWR meter. The output voltage polarity is negative, unless Option 003 is selected. The frequency range of the 423B is 10 MHz to 12.4 GHz. The 8470B's frequency range extends from 10 MHz to 18 GHz.

## 8. Options

9. The 423B and 8470B Crystal Detectors are available with the following options (see Table 1 for further descriptions):

- Option 001: Matched pair of detectors
- Option 002: Furnished with matched load resistor for optimum square law characteristics
- Option 003: Positive polarity output
- Option 012: Furnished with stainless steel type N male connectors (8470B only).

## 10. INSTALLATION

### 11. Initial Inspection

12. Inspect the shipping container for damage. If the shipping container or cushioning material is damaged, it should be kept until the contents of the shipment have been checked for completeness

and the instrument has been checked mechanically and electrically.

13. The procedures for checking electrical performance are given under PERFORMANCE TESTS. If the contents are incomplete, if there is mechanical damage or defect, or if the instrument does not pass the electrical performance test, notify the nearest Hewlett-Packard office. If the shipping container is damaged, or the cushioning material shows signs of stress, notify the carrier as well as the Hewlett-Packard office. Keep the shipping materials for the carrier's inspection. The HP office will arrange for repair or replacement without waiting for claim settlement.

## 14. Mating Connectors

15. The mating RF input connectors used with the 423B and the 8470B Option 012 must be Type N female connectors which comply with U.S. military standard MIL-C-39012. The 8470B (standard) RF input connector must be an APC-7 type connector. The mating output connector for the 423B and 8470B must be a BNC male.

## 16. Operating Environment

17. The operating environment of the crystal detectors should be within the following limitations:

- a. Temperature:  $-20^{\circ}\text{C}$  to  $+85^{\circ}\text{C}$  (8470B) and 0 to  $+55^{\circ}\text{C}$  (423B).
- b. Altitude: <4570 metres (15,000 feet).
- c. Humidity: <95% relative
- d. Shock: 100G for 11 ms
- e. Vibration: 20G from 80 to 2000 Hz.

## 18. STORAGE AND SHIPMENT

19. **Environment.** The instrument should be stored in a clean, dry environment. The following environmental limitations apply to both storage and shipment:

- a. Temperature:  $-54^{\circ}\text{C}$  to  $+85^{\circ}\text{C}$
- b. Humidity: <95% relative
- c. Altitude: <7620 metres (25,000 feet)
- d. Shock: 100G for 11 ms.
- e. Vibration: 20G from 80 to 2000 Hz.

Table 1. Specifications

**Frequency Range:**

423B: 10 MHz to 12.4 GHz

8470B: 10 MHz to 18 GHz

**NOTE**

*RF may leak through the output connector, especially below 1 GHz. It can be reduced, if objectionable, with a suitable low pass filter.*

**Frequency Response:**<sup>1,2</sup>423B:  $\pm 0.2$  dB over any octave10 MHz to 8 GHz;  $\pm 0.3$  dB

10 MHz to 12.4 GHz.

8470B:  $\pm 0.2$  dB over any octave10 MHz to 8 GHz;  $\pm 0.3$  dB10 MHz to 12.4 GHz;  $\pm 0.5$  dB10 MHz to 15 GHz;  $\pm 0.6$  dB

10 MHz to 18 GHz.

**Maximum Operating Input Power:** 200 mW, peak or average.

**Maximum Short Term Input Power:** 1 watt (typical) peak or average for  $< 1$  minute.

**Sensitivity:**<sup>1, 3</sup>High Level:  $< 0.3$  mW produces 100 mV output.Low Level:  $> 0.5$  mVdc/ $\mu$ W CW.**SWR:**<sup>1,2</sup>

423B and 8470B: 10 MHz to 4 GHz, 1.15;

4 GHz to 12.4 GHz, 1.3.

8470B: 4 GHz to 15 GHz, 1.3; 15 GHz to

18 GHz, 1.4.

**Input Impedance:** 50 $\Omega$  (nominal)

**Output Impedance:**<sup>2</sup> 1 to 2 k $\Omega$  (typically 1.3 k $\Omega$ ) shunted by 20 to 60 pF (typically 30 pF).

**Output Polarity:** Negative (refer to Options for positive polarity units).

**Detector Element:** Supplied (refer to Table 2 for replacement elements).

**Bias:** Not required.

**Noise:**  $< 50$   $\mu$ V p-p with CW applied to produce 100 mV output.

<sup>1</sup>Specifications given for  $+25^\circ\text{C}$  unless otherwise noted.

<sup>2</sup>Measurement made at  $-20$  dBm.

<sup>3</sup>Sensitivity decreases with increasing temperature, typically:  
0.5 dB from  $-20^\circ\text{C}$  to  $+25^\circ\text{C}$ ; 0.5 dB from  $+25^\circ\text{C}$  to  $+40^\circ\text{C}$ ;  
1 dB from  $+40^\circ\text{C}$  to  $+55^\circ\text{C}$ ; 1.25 dB from  $+55^\circ\text{C}$  to  $+75^\circ\text{C}$ ;  
1 dB from  $+75^\circ\text{C}$  to  $+85^\circ\text{C}$ .

**Options:****423B:**

Option 001: Matched detector pair. Frequency response characteristics (exclusive of basic sensitivity) track within  $\pm 0.2$  dB from 10 MHz to 12.4 GHz.

Option 002: Furnished with matched Load Resistor for optimum square law characteristics at  $25^\circ\text{C}$ , within  $\pm 0.5$  dB from square law over a range of at least 30 dB up to 10 mV peak output working into an external load  $> 0.1$  mV/ $\mu$ W when load resistor is used.

Option 003: Positive polarity output.

**8470B:**

Option 001: Matched detector pair. Frequency response characteristics (exclusive of basic sensitivity) track within  $\pm 0.2$  dB from 10 MHz to 12.5 GHz;  $\pm 0.3$  dB from 12.4 GHz to 18 GHz.

Option 002: Furnished with matched Load Resistor for optimum square law characteristics of  $25^\circ\text{C}$ , within  $\pm 0.5$  dB from square law over a range of at least 30 dB up to 10 mV peak output working into an external load  $> 8$  k $\Omega$ . Sensitivity typically  $> 0.1$  mV/ $\mu$ W when load resistor is used.

Option 003: Positive polarity output.

Option 012: Furnished with stainless steel type N male connector.

**Environmental:****423B:**Operating Temperature:  $0^\circ\text{C}$  to  $+55^\circ\text{C}$ Humidity:  $< 95\%$  relative

Vibration: 20G from 80 to 2000 Hz.

Shock: 100G for 11 ms.

Altitude: 4570m (15,000 ft.)

**8470B:**Operating Temperature:  $-20^\circ\text{C}$  to  $+85^\circ\text{C}$ .Humidity:  $< 95\%$  relative

Vibration: 20G from 80 to 2000 Hz.

Shock: 100G for 11 ms.

Altitude: 4570m (15,000 ft.).

**General:**

Weight: Net 114 g (4 oz.) 423B and 8470B.

**Dimensions:**

423B: 63 mm long, 20 mm diameter (2.47 in. long, 0.78 in. diameter).

8470B: 64 mm long, 19 mm diameter (2.50 in. long, 0.75 in. diameter).

**20. Original Packaging.** Containers and materials identical to those used in factory packaging are available through Hewlett-Packard offices. If the instrument is being returned to Hewlett-Packard for servicing, attach a tag indicating the type of service required, return address, model number, and serial number. Also, mark the container FRA-GILE to assure careful handling. In any correspondence, refer to the instrument by model number and serial number.

## 21. OPERATION

### CAUTIONS

Static discharge can damage the detector element. A 100 pF capacitor (1.2 m [4 ft.] of coax cable) charged to 14 volts stores .1 erg, the maximum pulse rating of the detector element. Connect cables to test equipment and discharge the center conductor before connecting to the detector.

**DO NOT NEEDLESSLY HANDLE DETECTOR ELEMENT USED IN CRYSTAL DETECTOR.** Static electricity which builds up on a person, especially on a cold dry day, must never be allowed to discharge through the crystal detector. Avoid exposed leads to or from the crystal detector, since these are often touched accidentally.

## 22. Operating Information

23. The crystal detector can be used as a demodulator to obtain a pulse envelope which can then be observed on an oscilloscope. It can also be used as a general purpose detector.

24. When using the crystal detector with an oscilloscope, and the waveshapes to be observed have rise times of less than  $5 \mu\text{s}$ , the coaxial cable connecting oscilloscope and detector should be as short as possible and shunted with a resistor. Ideally, this resistor should be  $50\Omega$  to terminate the coaxial cable properly. However, with  $50\Omega$  resistance, the output video pulse may be too small to drive some oscilloscopes. Therefore, the cable should be shunted with the smallest value of resistance that will obtain suitable deflection on the oscilloscope; typically the value will lie between  $50\Omega$  and  $2\text{k}\Omega$ . The larger the resistance the more degradation of rise time.

25. The power applied to the detector can be either modulated or continuous wave (CW). If modulated at a 1000 Hz rate, an SWR meter can be used as an indicator. For CW detection, a dc milliammeter or millivoltmeter can be used as the indicator.

## 26. Operator's Checks

**27. Peak Power Measurement.** The arrangement of equipment for peak power measurement is shown in Figure 1. The procedure involves calibration of an oscilloscope which, in turn, is used to calibrate a CW generator. The output of the calibrated CW generator is measured with a power meter; the peak power of a pulse is thereby measured. The procedure is as follows:

- Connect equipment as shown in Figure 1, step a. Observe pulse on a dc-coupled oscilloscope. Using a marking pencil, mark on the graticule the base-to-peak amplitude of the pulse envelope.
- Replace the pulse source with a CW generator. While observing the oscilloscope trace, adjust amplitude of CW generator output to make detector's output equal to that of pulse generator, as indicated by markings on graticule (step a).
- Leave CW generator at setting obtained in step b. Disconnect detector from CW generator.

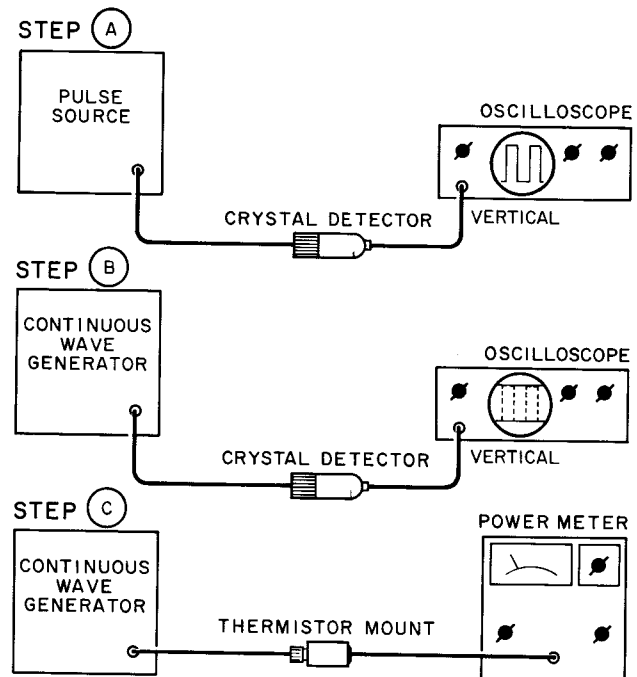

Figure 1. Peak Power Measurement

Connect output of CW generator to power meter. Measure adjusted levels (set in step b) of CW generator output. The peak power of the pulse envelope observed in step a is equal to the output power of the CW generator.

**28. Reflectometer Application.** For information about reflectometer systems and measurements, see HP Application Note Index, copies of which are available upon request.

**29. Harmonic Frequency Comparison Measurement Application.** The detector can be used as a mixer in harmonic-frequency comparison measurements (see HP Application Note Index for further information).

### 30. PERFORMANCE TESTS

31. The following paragraphs suggest methods to use for testing detector specifications. For these tests refer to the manuals of the equipment involved for operating instructions.

### 32. Frequency Response Test

a. Using signal sources covering 10 MHz to 18 GHz with a 10 dB isolating attenuator and a power meter, connect power sensor to attenuator. Adjust RF power level to  $-20$  dBm input to power sensor.

b. Without changing RF power level of signal source, disconnect power sensor.

c. Connect detector to attenuator. Measure dc voltage output from detector and record measurement.

d. Change frequency of signal source and repeat steps a through c.

e. Since the detector follows a square-law response at this power level, its output is proportional to power ( $P_{dB} = 10 \log V_O$ ). Total variation of detector readings should meet specifications (see Table 1) for all frequencies of interest across the band.

#### NOTE

*Multiple mismatch errors caused by attenuator SWR, power meter SWR, and detector SWR should be taken into account, as well as the accuracy of the indicator used to measure the detector's output.*

### 33. High Level Sensitivity Test

a. Using signal sources covering 10 MHz to 18 GHz and a dc voltmeter or oscilloscope as the indicator, connect detector to signal source. Adjust RF power level for a 100 mV detected output from detector.

b. Disconnect detector from signal source and measure RF output level. The RF output level should be  $\leq 0.35$  mW.

c. Repeat steps a and b for all frequencies of interest across the band.

### 34. Low Level Sensitivity Test

a. Using a signal source (covering 100 MHz to 2 GHz), a 10 dB attenuator, and a power meter, connect attenuator to signal source and power sensor to attenuator. Adjust RF power level for  $-20$  dBm output from attenuator. Verify the ambient temperature.

b. Disconnect power sensor from attenuator and connect detector. Measure the dc voltage output from detector. The output should be  $> 5.0$  mV at  $25^\circ\text{C}$ . Between  $20^\circ\text{C}$  and  $30^\circ\text{C}$  the sensitivity slope is typically  $-0.04$  dB/ $^\circ\text{C}$ .

#### NOTE

*Multiple mismatch errors caused by attenuator SWR, power meter SWR, and detector SWR should be taken into account, as well as accuracy of indicator used to measure detector's output.*

### 35. Match Test (SWR)

36. To verify the detector's SWR specifications, use any system whose measurement accuracies for SWR (residual SWR) are known.

### 37. ADJUSTMENTS

38. The detectors have no internal adjustments.

### 39. REPLACEABLE PARTS

40. The succeeding paragraphs contain information pertaining to replaceable parts (see Table 2) and the ordering of replaceable parts for the Models 423B, 8470B, and the Load Resistor.

41. To order a replacement part, address order or inquiry to the nearest Hewlett-Packard office (see

list in back of manual.) Include the following information for each part: model number, Hewlett-Packard part number, and description.

## 42. SERVICE

43. The succeeding paragraphs give instructions for repair of the Model 423B and 8470B Crystal Detectors and the Option 002 Load Resistor. Additional maintenance information can be obtained from the local Hewlett-Packard office. Part numbers for replaceable parts are given in Table 2.

## 44. Detector Element Replacement

45. The detector element assembly includes only a detector element, unless an Option 002 is ordered, then a resistor for the Load Resistor is included. The resistor is to load the diode for square-law operation.

### CAUTION

The special detector element (see Figures 4 and 5) contained in the detector can be damaged in handling, removal, or installation if certain precautions are not taken. The handling precautions which follow should be read before performance of any operation with the detector element when it is out of either the housing or the detector element shipping container.

- a. Before installing diode into mount, touch exposed metal on mount with your hand to discharge static electricity. Then insert diode into mount.
- b. When handing diode to another person, touch hands first to ensure there is no difference in static electricity potential between you.
- c. Ohmmeters should not be used to measure forward- and back-resistance since it is easy to damage these diodes. The difficulty arises because of the ohmmeter's open-circuit voltages and short-circuit currents.

## 46. Replacing Detector Element

47. Parts mentioned in the following procedure are identified in Figures 4 and 5.

- a. Remove female BNC connector and compression spring from inside of the connector cap.

- b. Remove connector cap from body. To remove connector cap, use a pair of pliers with plastic jaws or protect body with heavy paper or tape.

### CAUTION

Do not rotate detector element while inserting or removing or damage may result.

When inserting detector element, do not force the large pin end into the center conductor in the body. The fingers of the center conductor or the detector element might be damaged if the detector element is not centered.

- c. Remove old detector element, axial spacer, and RF washer and discard the detector element.
- d. Install the RF washer, axial spacer, and new detector element. Figures 4 and 5 show the proper orientation for the internal components. Insert the RF adapter washer first; then carefully insert the large pin end of the detector element into the center contact inside the detector body. Place the axial spacer over the small pin end of the detector element.
- e. Carefully place the connector cap over the body and assembled components and tighten firmly in place.
- f. Place the compression spring into the center conductor of the female BNC connector. Carefully start the spring over the small pin of the detector element through the hole in the connector cap. Keep the spring in the BNC center conductor and screw the female BNC connector firmly into place.

## 48. Replacement of Load Resistor Parts

49. Parts mentioned in the following procedure are identified in Figures 2 and 3.

## 50. Replacing Male BNC Connector

- a. Remove male BNC connector and lock washer from housing. To remove BNC connector, use a 3/8-inch open-end wrench and hold the housing either in a vise or with pliers. Before using the vise or pliers, protect the housing of the Load Resistor with material such as heavy paper or tape or use plastic jaws on the vise or pliers.
- b. Unsolder resistor.

- c. Solder resistor to new BNC connector.
- d. Let resistor cool and then check resistance from male BNC pin through resistor; resistance measured should be  $\pm 10\%$  that indicated by the color coding.
- e. Replace lockwasher and male BNC connector.

### 51. Replacing Female BNC Connector

- a. Remove female BNC connector. To remove or install BNC connector, use a BNC wrench or use a male BNC connector as a wrench to prevent damage to the connector.
- b. Unsolder contact spring.
- c. Prepare replacement female BNC connector:
  - (1) Cut center conductor lead to approximately 0.79 mm (1/32 in.)
  - (2) With flat file, smooth end of lead; remove burr with tweezers or similar metal instrument.
- d. Slip contact spring over center conductor lead, and solder.

#### CAUTION

Use solder sparingly or it will creep back on spring. Solder on spring destroys its usefulness and is difficult to remove.

- e. Let contact spring cool and then screw connector into mount.

### 52. Replacement of APC-7 Connector Center Contact

53. The replacement procedure for the APC-7 connector center contact is covered in Figure 7.

The disassembly and assembly instructions for the APC-7 connector is covered in Figure 6.

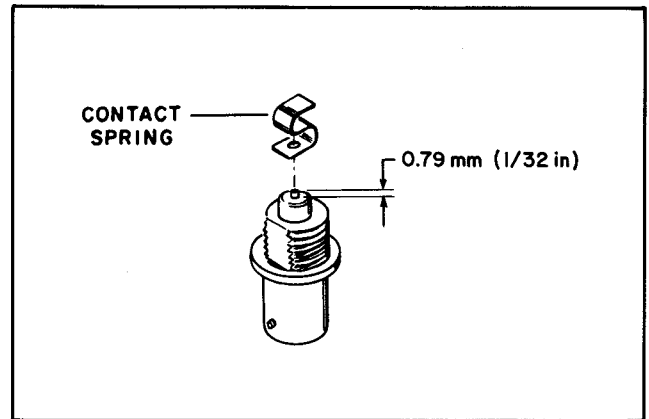

Figure 2. Cutting Center Conductor Lead to Accommodate Contact Spring

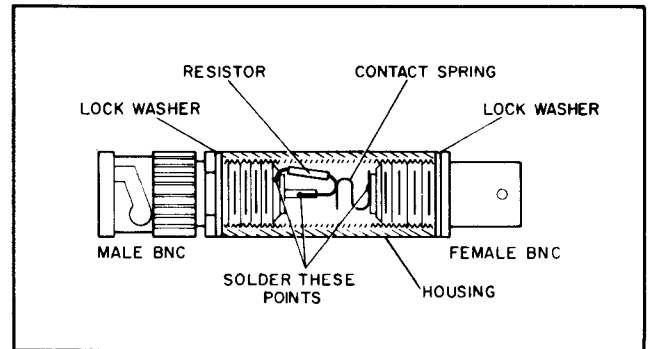

Figure 3. Load Resistor, Cutaway View

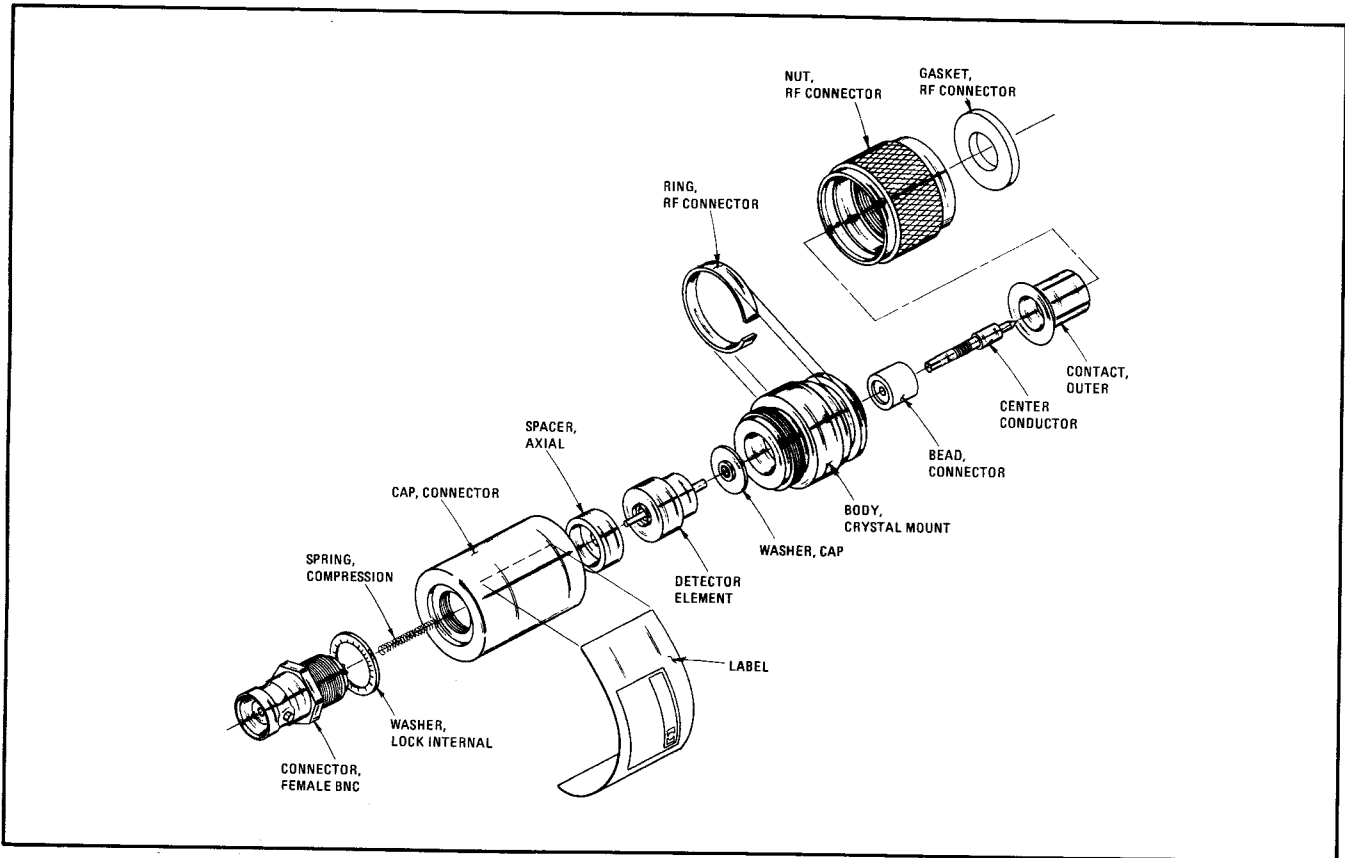

Figure 4. HP Model 423B Crystal Detector Assembly

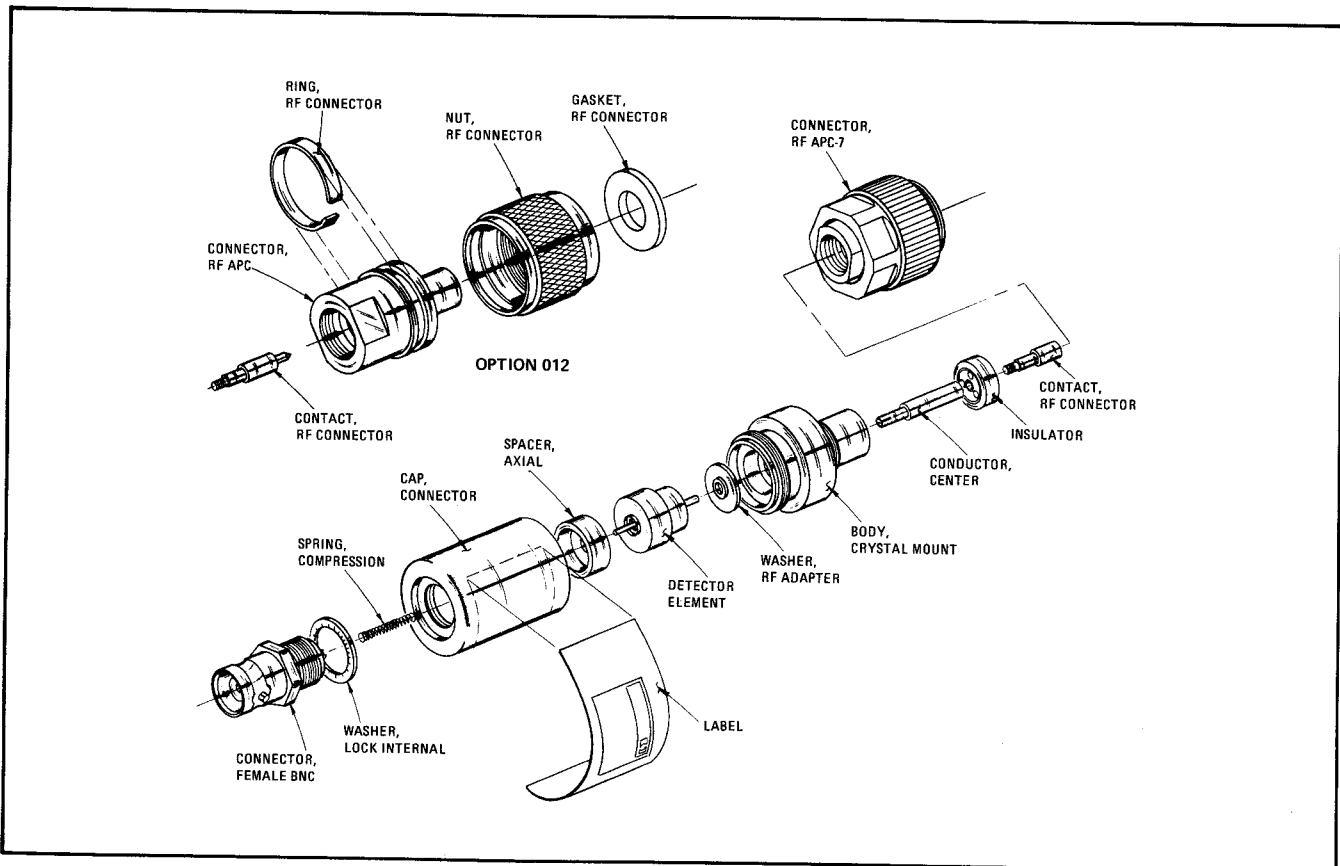
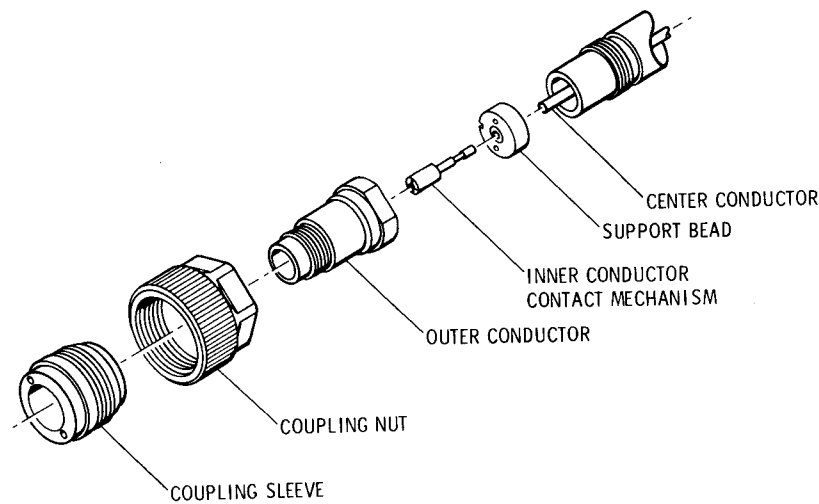

Figure 5. HP Model 8470B and 8470B Option 012 Crystal Detector Assemblies



Table 2. Replaceable Parts, Models 423B, 8470B and 11523A

Description	Part Number	Description	Part Number
<b>423B Assembly</b>		Spring, Compression	1460-0072
Conductor, Center	1250-0014	Washer, Lock Internal	2190-0016
Gasket, RF Connector	1250-0015	Cap, Connector	5020-0210
Ring, RF Connector	1250-0016	Washer, Cap	5021-0127
Connector, Female BNC	1250-0212	Spacer, Axial	5020-8598
Nut, RF Connector	1250-0918	Insulator	5040-0306
Spring, Compression	1460-0072	Body, Crystal Mount	08470-2000
Washer, Lock Internal	2190-0016	Conductor, Center	08470-20002
Bead, Connector	5020-0207	Ring, RF Connector (Opt. 012)	1250-0016
Cap, Connector	5020-0210	Connector, RF APC (Opt. 012)	1250-0916
Washer, Cap	5021-0127	Contact, RF Connector (Opt. 012)	1250-0917
Spacer, Axial	5020-8598	Nut, RF Connector (Opt. 012)	1250-0918
Contact, Outer	00423-201		
Body, Crystal Mount	00423-202	<b>Replacement Diode Assemblies<sup>1</sup></b>	
<b>Replacement Diode Assemblies<sup>1</sup></b>		Single Diode Negative Polarity	08470-60012
Single Diode Negative Polarity	00423-60003	Single Diode Positive Polarity (Opt. 003)	08470-60013
Single Diode Positive Polarity (Opt 003)	00423-60004	Single Diode w/ Matching Load Resistor Negative Polarity (Opt. 002)	08470-60014
Single Diode Negative Polarity with Matching Load Resistor (Opt 002)	00423-60005	Single Diode w/ Matching Load Resistor Positive Polarity (Opt. 002, 003)	08470-60015
Single Diode Positive Polarity with Matching Load Resistor (Opt 002 and 003)	00423-60006	Matched Pair Diodes Negative Polarity (Opt. 001)	08470-60016
Matched Pair Diodes Negative Polarity (Opt 001)	00423-60007	Matched Pair Diodes Positive Polarity (Opt. 001, 003)	08470-60017
Matched Pair Diodes Positive Polarity (Opt 001, 003)	00423-60008	Matched Pair Diodes w/ Load Resistor Negative Polarity (Opt. 002)	08470-60018
Matched Pair Diodes with Load Resis- tor Negative Polarity (Opt 002)	00423-60009	Matched Pair Diodes w/Load Resistor Positive Polarity (Opt. 002, 003)	08470-60019
Matched Pair Diode with Load Resis- tor Positive Polarity (Opt 002,003)	00423-60011	<b>8470B APC-7 Connector Assembly</b>	
<b>11523A Load Resistor Assembly<sup>1</sup></b>		Inner Conductor Contact Mechanism (assembled contact and outer body)	1250-0816
Connector, Male BNC	1250-0045	Coupling Nut	1250-0819
Connector, Female BNC	1250-0251	Coupling Sleeve	1250-0820
Spring, Contact	5000-0234	Inner Conductor Contact	1250-0907
Housing	5020-3215	Outer Conductor	1250-1183
<b>8470B and 8470B-012 Assemblies<sup>1</sup></b>		Support Bead	5040-0306
Connector, Female BNC	1250-0212	Tools: <sup>2</sup>	
Contact, RF Connector	1250-0816	APC-7 Contact Extractor	5060-0236
Connector, RF APC-7	1250-0909	APC-7 Spanner Wrench	5060-0237
		Open-end Wrench	8710-0877
<sup>1</sup> Refer to Table 1 for description of options.			
<sup>2</sup> Part of HP Model 11591A APC-7 Connector Tool Kit.			



### USE

#### To Connect:

1. On one connector, retract the coupling sleeve by turning the coupling nut counterclockwise until the sleeve and nut disengage.
2. On the other connector, fully extend the coupling sleeve by turning the coupling nut clockwise. To engage coupling sleeve and coupling nut when the sleeve is fully retracted, press back lightly on the nut while turning it clockwise.
3. Push the connectors firmly together, and thread the coupling nut of the connector with retracted sleeve over the extended sleeve.
4. Close the gap between coupling nuts with the nut on the extended-sleeve connector.

#### To Disconnect:

1. Loosen the coupling nut of the connector showing the wider gold band.

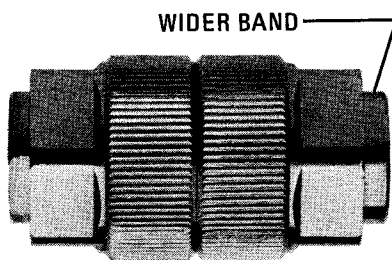

2. **IMPORTANT:** Part the connectors carefully to prevent striking the inner conductor contact.

### CARE

1. Keep contacting surfaces smooth and clean. Irregularities and foreign particles can degrade electrical performance.

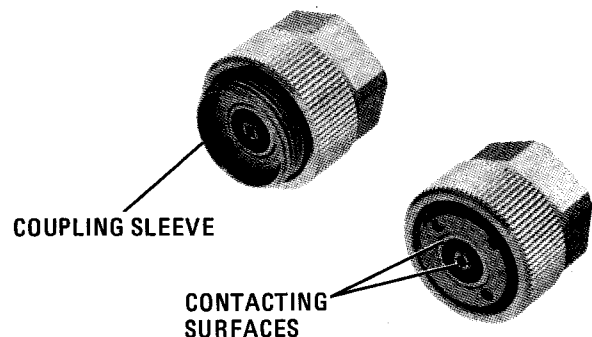

2. Protect the contacting surfaces when the connector is not in use by leaving the coupling sleeve extended.
3. Use lintless material and/or firm-bristled brush such as a tooth brush for cleaning. If a cleaning fluid is needed use isopropyl alcohol. **IMPORTANT:** Do not use aromatic or chlorinated hydrocarbons, esters, ethers, terpenes, higher alcohols, ketones, or ether-alcohols such as benzene, toluene, turpentine, dioxane, gasoline, cellosolve acetate, or carbon tetrachloride. Keep exposure of the connector parts to both the cleaning fluid and its vapors as brief as possible.

Figure 6. APC-7 Connectors

### REPLACING AMPHENOL APC-7 CENTER CONTACT

Through wear or damage the contact in the center conductor may need replacing. This contact is a small four-pronged collet which snaps into a recess in the center conductor. This contact is normally held in by the spring-action of the four prongs. With a magnifying glass, examine this contact to determine if it needs replacement. **DO NOT REMOVE THIS CONTACT FOR INSPECTION** (it may be damaged by removal). The contact should be free of burrs or wear and the prongs should be equally spaced. If the contact is removed, do **NOT** re-use it (it may be damaged by removal). This contact is Amphenol\* part number 131-129 and HP 1250-0907. If this contact needs replacement and a new contact is available, proceed as follows:

1. Place the instrument so the connector faces down, if possible.
2. Tap the connector lightly and the contact should now protrude slightly. Insert the centering pin of the Hewlett-Packard collet remover, Part Number 5060-0236, with the jaws open.
3. Allow the jaws on the tool used to close and pull straight back from the connector without twisting. The contact should come with the tool. If not, repeat the process. Do **NOT** re-use the contact.

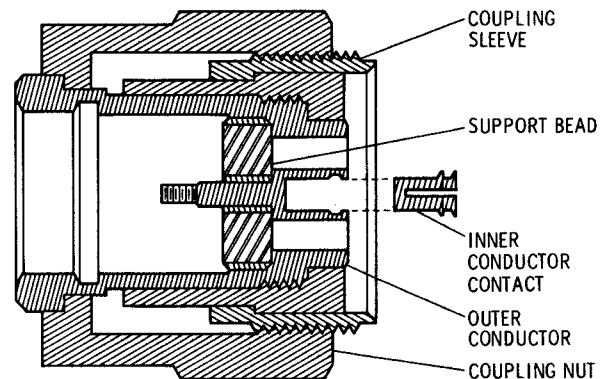

4. Snap in a new contact by pushing a new contact in place. Test the action of the new contact by pushing in on it. It should spring out again when released.

(Amphenol\* Part Number 131-129; HP Part Number 1250-0907.)

\*Amphenol RF Division, Danbury, Conn.

Figure 7. APC-7 Connector

## CERTIFICATION

*The Hewlett-Packard Company certifies that this instrument met its published specifications at the time of shipment from the factory. Hewlett-Packard Company further certifies that its calibration measurements are traceable to the United States National Bureau of Standards, to the extent allowed by the Bureau's calibration facility, and to the calibration facilities of other International Standards Organization members.*

## WARRANTY AND ASSISTANCE

This Hewlett-Packard product is warranted against defects in materials and workmanship for a period of one year from the date of shipment. Hewlett-Packard will, at its option, repair or replace products which prove to be defective during the warranty period provided they are returned to Hewlett-Packard. Repairs necessitated by misuse of the product are not covered by this warranty. **NO OTHER WARRANTIES ARE EXPRESSED OR IMPLIED, INCLUDING, BUT NOT LIMITED TO, THE IMPLIED WARRANTIES OF MERCHANTABILITY AND FITNESS FOR A PARTICULAR PURPOSE. HEWLETT-PACKARD IS NOT LIABLE FOR CONSEQUENTIAL DAMAGES.**

Service contracts or customer assistance agreements are available for Hewlett-Packard products.

For any assistance, contact your nearest Hewlett-Packard Sales and Service Office.

## HEWLETT-PACKARD SERVICE OFFICES

To obtain servicing information, contact the nearest Hewlett-Packard Sales and Service Office in HP Catalog, or contact the nearest regional office listed below.

### UNITED STATES

#### CALIFORNIA

333 Logue Ave.  
Mt. View, CA 94043  
or 6315 Arizona Place  
Los Angeles, CA 90045

#### GEORGIA

P.O. Box 105005  
Atlanta, GA 30348

#### ILLINOIS

5201 Tollview Dr.  
Rolling Meadows, IL 60008

#### NEW JERSEY

W. 120 Century Rd.  
Paramus, NJ 07652

### AUSTRALIA

Hewlett-Packard Australia Pty, Ltd.  
P.O. Box 36  
Doncaster East, Victoria 3109

### CANADA

Hewlett-Packard (Canada) Ltd.  
6877 Goreway Drive  
Mississauga, Ontario  
Canada L4V 1M8

### EUROPE

#### FRANCE

Hewlett-Packard France  
Quartier de Courtaboeuf  
Boite Postale No. 6  
F-91401 Orsay Cedex

#### GERMAN FEDERAL REPUBLIC

Hewlett-Packard GmbH  
Vertriebszentrale Frankfurt  
Bernerstrasse 117  
Postfach 560 140  
D-6000 Frankfurt 56

#### NETHERLANDS

Hewlett-Packard Benelux N.V.  
Van Heuven Goedhartlaan 121  
P.O. Box 667  
NL-Amstelveen 1134

#### SWITZERLAND

Hewlett-Packard (Schweiz) AG  
Zurcherstrasse 20  
P.O. Box 307  
CH-8952 Schlieren-Zurich

#### UNITED KINGDOM

Hewlett-Packard Ltd.  
King Street Lane  
GB-Winnersh, Wokingham  
Bers. RG11 5AR

### AFRICA, ASIA, CENTRAL AND SOUTH AMERICA

Hewlett-Packard Intercontinental  
3200 Hillview Avenue  
Palo Alto, CA 94304

